



PRO SERIES



Borroughs Next Generation Pro Series

Complete Service Bay Work Centers



Next Generation Pro Series System

How To Configure A Borroughs Next Generation Pro Series System

PRO SERIES

1. Select bench top size and material (page 3)
2. Select base cabinet sizes and configurations (page 2-3) (add base cabinet platforms (page 3) if desired)
3. Select accessory cabinets (page 4)
4. Select upper cabinets (page 5)
5. Select accessories (carts, tool boxes, chase panels, risers etc.)



Base Cabinets

Features/ Benefits

The Next Generation Pro Series is completely modular, making the system easy to configure and install. Welded and reinforced to give unsurpassed durability, Next Generation Pro Series systems will look great, even after years of service.

- Base cabinets are welded and reinforced.
- All base cabinets are 28" deep and 33" high.
- Painted or stainless steel platforms can be added to achieve desired working height.
- Base cabinets can be configured with one of four drawer configurations, doors, service panels (for hose reels) or open shelves.
- Lift motor drawers are available for 14" wide cabinets.
- All handles, locks and hinges are fully recessed to eliminate snagging or tripping hazards.
- Swing doors allow 100% access to cabinet contents.
- Tool storage drawers have 500 lb. capacity ball bearing slides, combining smooth action and super weight capacity.



Base Cabinets

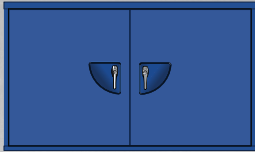

2833561



2833562



2833563



2833564



2833565

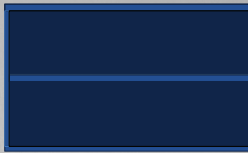

2833566



2833567

56" Wide - All base cabinets are 28" deep and 33" high

- 2833561 56" x 33" x 28"D base cabinet with locking swing out doors and adjustable center shelf
- 2833562 56" x 33" x 28"D base cabinet with drawer configuration 1
- 2833563 56" x 33" x 28"D base cabinet with drawer configuration 2
- 2833564 56" x 33" x 28"D base cabinet with drawer configuration 3
- 2833565 56" x 33" x 28"D base cabinet with drawer configuration 4
- 2833566 56" x 33" x 28"D base cabinet with center shelf and no doors
- 2833567 56" x 33" x 28"D base cabinet with configurable service panel for hose reels

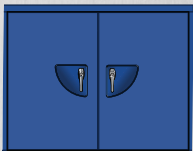

2833421



2833422



2833423



2833424

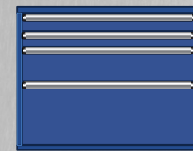

2833425

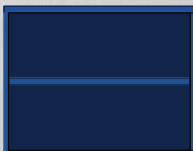

2833426

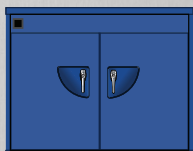

2833427

42" Wide - All base cabinets are 28" deep and 33" high

- 2833421 42" x 33" x 28"D base cabinet with locking swing out doors and adjustable center shelf
- 2833422 42" x 33" x 28"D base cabinet with drawer configuration 1
- 2833423 42" x 33" x 28"D base cabinet with drawer configuration 2
- 2833424 42" x 33" x 28"D base cabinet with drawer configuration 3
- 2833425 42" x 33" x 28"D base cabinet with drawer configuration 4
- 2833426 42" x 33" x 28"D base cabinet with center shelf and no doors
- 2833427 42" x 33" x 28"D base cabinet with configurable service panel for hose reels

4 different drawer configurations

Configuration 1

Two 3.5" drawers
Three 7.5" drawers

Configuration 2

Four 3.5" drawers
Two 7.5" drawers

Configuration 3

Three 3.5" drawers
One 7.5" drawer
One 11" drawer

Configuration 4

Two 3.5" drawers
One 7.5" drawer
One 14.5" drawer

Base Cabinets



2833281



2833282



2833283



2833284



2833285



2833286



2833287

28" Wide - All base cabinets are 28" deep and 33" high

- 2833281 28" x 33" x 28"D base cabinet with locking swing out doors and adjustable center shelf
- 2833282 28" x 33" x 28"D base cabinet with drawer configuration 1
- 2833283 28" x 33" x 28"D base cabinet with drawer configuration 2
- 2833284 28" x 33" x 28"D base cabinet with drawer configuration 3
- 2833285 28" x 33" x 28"D base cabinet with drawer configuration 4
- 2833286 28" x 33" x 28"D base cabinet with center shelf and no doors
- 2833287 28" x 33" x 28"D base cabinet with configurable service panel for hose reels



2833141



2833142



2833143



2833144

14" Wide - All base cabinets are 28" deep and 33" high

- 2833141 14" x 33" x 28"D base cabinet with pump drawer - Rotary InBay
- 2833142 14" x 33" x 28"D base cabinet with pump drawer - Rotary Mechanical
- 2833143 14" x 33" x 28"D base cabinet with pump drawer - Challenger
- 2833144 14" x 33" x 28"D base cabinet with center shelf

4 different drawer configurations

Configuration 1

- Two 3.5" drawers
- Three 7.5" drawers

Configuration 2

- Four 3.5" drawers
- Two 7.5" drawers

Configuration 3

- Three 3.5" drawers
- One 7.5" drawer
- One 11" drawer

Configuration 4

- Two 3.5" drawers
- One 7.5" drawer
- One 14.5" drawer

Optional Base Cabinet Platforms

Stainless Steel

- 281400 14" x 28" x 3" high welded stainless steel platform
- 282800 28" x 28" x 3" high welded stainless steel platform
- 284200 42" x 28" x 3" high welded stainless steel platform
- 285600 56" x 28" x 3" high welded stainless steel platform
- 281401 14" x 28" x 6" high welded stainless steel platform
- 282801 28" x 28" x 6" high welded stainless steel platform
- 284201 42" x 28" x 6" high welded stainless steel platform
- 285601 56" x 28" x 6" high welded stainless steel platform

Painted

- 281402 14" x 28" x 3" high welded painted platform
- 282802 28" x 28" x 3" high welded painted platform
- 284202 42" x 28" x 3" high welded painted platform
- 285602 56" x 28" x 3" high welded painted platform
- 281403 14" x 28" x 6" high welded painted platform
- 282803 28" x 28" x 6" high welded painted platform
- 284203 42" x 28" x 6" high welded painted platform
- 285603 56" x 28" x 6" high welded painted platform

Bench Tops

Stainless Steel over Wood Core

- 303600 36" w x 30" d x 1 1/2" high stainless steel over wood core top
- 304800 48" w x 30" d x 1 1/2" high stainless steel over wood core top
- 306000 60" w x 30" d x 1 1/2" high stainless steel over wood core top
- 307200 72" w x 30" d x 1 1/2" high stainless steel over wood core top
- 308400 84" w x 30" d x 1 1/2" high stainless steel over wood core top
- 309600 96" w x 30" d x 1 1/2" high stainless steel over wood core top
- 301200 120" w x 30" d x 1 1/2" high stainless steel over wood core top

Painted Steel over Wood Core

- 303601 36" w x 30" d x 1 1/2" high painted steel over wood core top
- 304801 48" w x 30" d x 1 1/2" high painted steel over wood core top
- 306001 60" w x 30" d x 1 1/2" high painted steel over wood core top
- 307201 72" w x 30" d x 1 1/2" high painted steel over wood core top
- 308401 84" w x 30" d x 1 1/2" high painted steel over wood core top
- 309601 96" w x 30" d x 1 1/2" high painted steel over wood core top
- 301201 120" w x 30" d x 1 1/2" high painted steel over wood core top

Accessory Cabinets

Reel Cabinets

- Housings are all welded construction and come in two widths (28" and 42").
- Reel cabinets have an upper area for fluid reels and a lower area for electrical and air.
- Upper reels hang over a removable drip pan for easy clean up.
- Lower reels are recessed to keep them out of the way of foot traffic.
- All reel cabinets come with a standard accessory bin for alternate fittings.

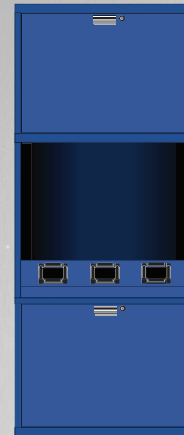

2828751

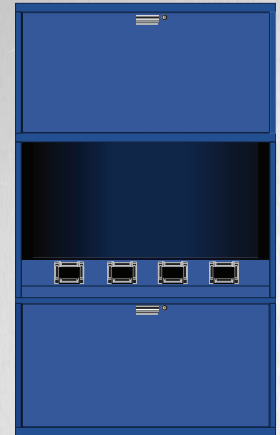

2842751

Reel Cabinets

2828751 28" x 28" x 75" high reel cabinet w/ three upper and three lower positions

2842751 42" x 28" x 75" high reel cabinet w/ four upper and four lower positions

Cart Storage Cabinets/ Wardrobe Combination Cabinets

- Housings are all welded construction and come in two widths (28" and 42").
- Cabinets come standard with locking swing out doors to keep carts secure and out of sight.
- Wardrobe cabinets also include an upper storage area for technician personal storage.



2828752

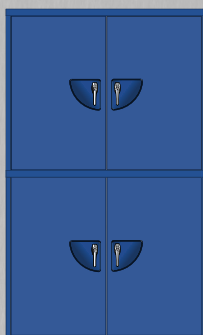

2842752

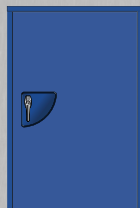

2828421

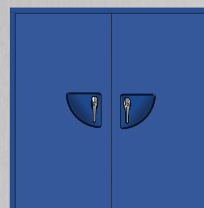

2842421



2828753

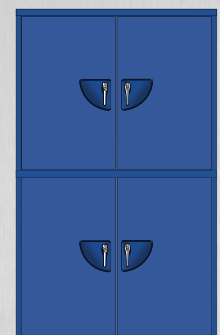

2842753

Cart Storage Cabinets/ Wardrobe Combination Cabinets

2828752 28" x 28" x 75" high cart storage locker with upper cabinet

2842752 42" x 28" x 75" high cart storage locker with upper cabinet

2828421 28" x 28" x 42" high cart storage locker

2842421 42" x 28" x 42" high cart storage locker

2828753 28" x 28" x 75" high cart storage locker with upper personal wardrobe cabinet

2842753 42" x 28" x 75" high cart storage locker with upper personal wardrobe cabinet

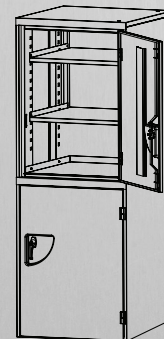

upper cabinet interior

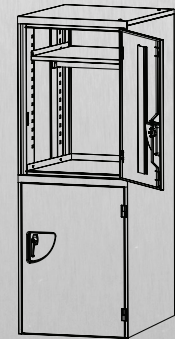

personal wardrobe interior

Upper Cabinets

Features / Benefits

- All welded construction provides ease of installation and years of service.
- Extra large capacity; standard height upper cabinets are 19" H x 20" deep.
- Extended height cabinets are 36" H x 20" deep.
- Standard height doors tip up and slide in on heavy duty ball bearing slides keeping the doors out of the way when cabinet is open.
- Monitor enclosures have plenty of room for up to a 17" flat panel screen.
- Articulating keyboard tray keeps the keyboard out of the way, but allows technicians to type at a comfortable height.



19614-005



19615-005



19615-007



19615-006

Standard Height - All cabinets are 19" high and 20" deep

19614-005	24" wide monitor cabinet w/ articulating keyboard tray
19615-005	36" wide upper cabinet with full height back and tip up/slide in door
19615-007	48" wide upper cabinet with full height back and tip up/slide in door
19615-006	60" wide upper cabinet with full height back and tip up/slide in door

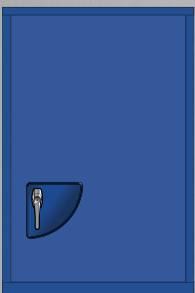

19614-015

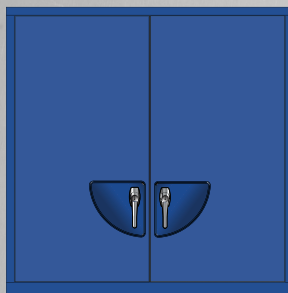

19615-015

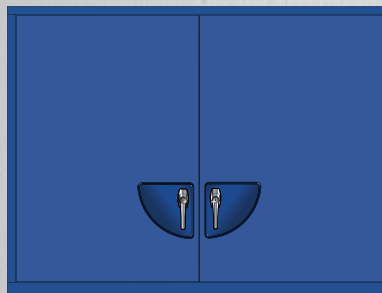

19615-017

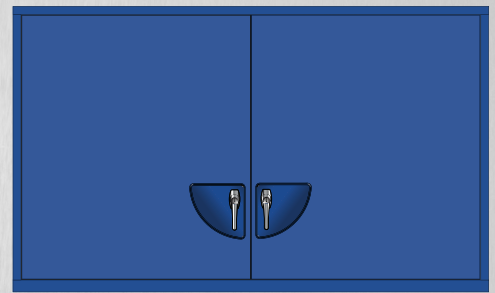

19615-016

Extended Height - All cabinets are 36" high and 20" deep

19614-015	24" wide upper cabinet with full height back, adjustable center shelf and lockable swing out doors
19615-015	36" wide upper cabinet with full height back, adjustable center shelf and lockable swing out doors
19615-017	48" wide upper cabinet with full height back, adjustable center shelf and lockable swing out doors
19615-016	60" wide upper cabinet with full height back, adjustable center shelf and lockable swing out doors

Tool Storage

Borroughs Corporation has always been known for quality. Borroughs Pro Series tool boxes are the highest quality boxes available. Paired with Borroughs Pro Series bench system, they make a statement of superior quality to your customers and employees.

PRO SERIES

BLTB-1

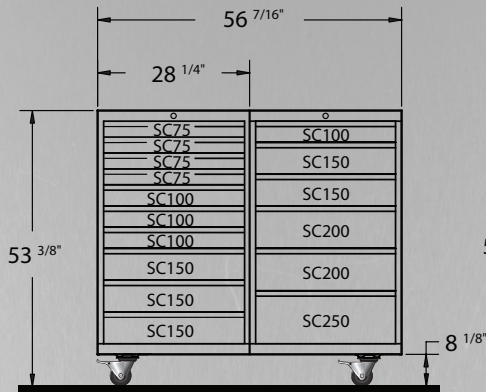

Overall dimensions are 56 ⁷/₁₆" wide x 28 ⁹/₁₆" deep x 53 ³/₈" high.

BLTB-2

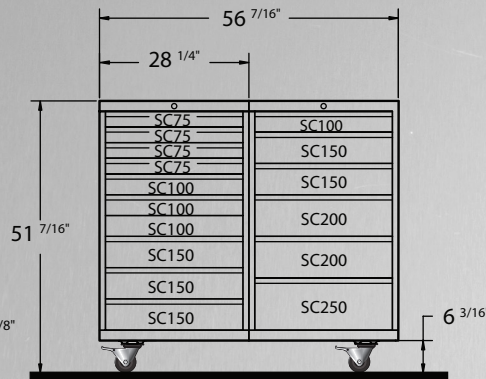

Overall dimensions are 56 ⁷/₁₆" wide x 28 ⁹/₁₆" deep x 51 ⁷/₁₆" high.

BLTB-3

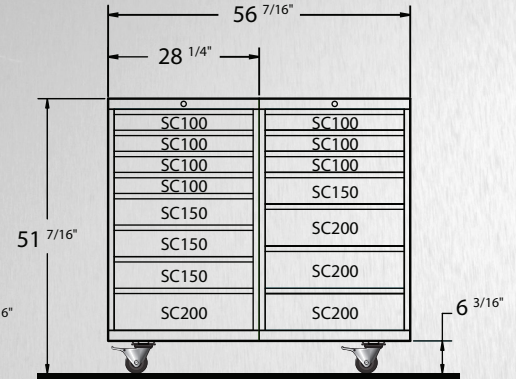

Overall dimensions are 56 ⁷/₁₆" wide x 28 ⁹/₁₆" deep x 51 ⁷/₁₆" high.

BLTB-4

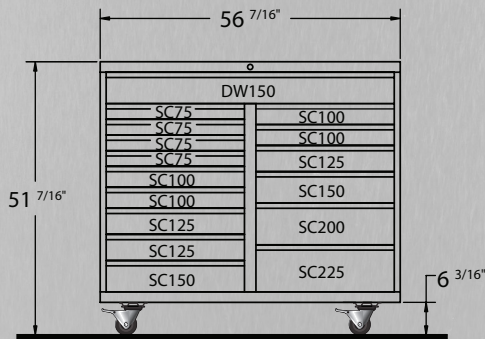

Overall dimensions are 56 ⁷/₁₆" wide x 28 ⁹/₁₆" deep x 51 ⁷/₁₆" high. One double-width top drawer.

BLTB-5

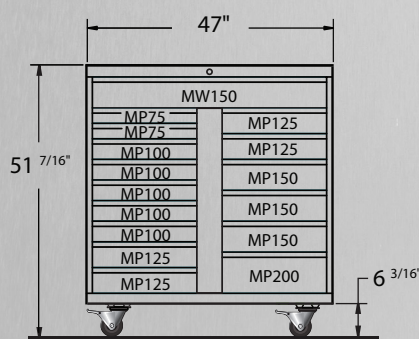

Overall dimensions are 47" wide x 28 ⁹/₁₆" deep x 51 ⁷/₁₆" high. One mid-width top drawer.

BLTB-6

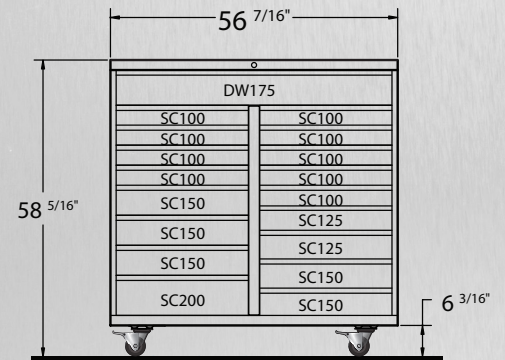

Overall dimensions are 56 ⁷/₁₆" wide x 28 ⁹/₁₆" deep x 58 ⁵/₁₆" high. One double-width top drawer.

BDW3-1000

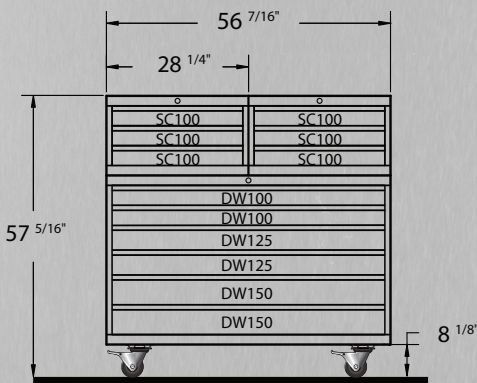

Overall dimensions are 56 ⁷/₁₆" wide x 28 ⁹/₁₆" deep x 57 ⁵/₁₆" high. Six double-width lower drawers.

Drawer Dimensions

- NW = Narrow Width
- SW = Standard Width
- MW = Mid-Width
- DW = Double-Width

Style	Width	Depth
NW	22 ³ / ₁₆ "	28 ¹ / ₂ "
SW	28 ¹ / ₄ "	28 ¹ / ₂ "
MW	47"	28 ¹ / ₂ "
DW	56 ¹ / ₂ "	28 ¹ / ₂ "

Drawer	Usable Height	Sidewall Height
75	2 ¹ / ₈ "	2"
100	3 ¹ / ₈ "	3"
125	4 ¹ / ₁₆ "	3"
150	5 ¹ / ₁₆ "	5"
175	6 ¹ / ₁₆ "	5"
200	7 ¹ / ₁₆ "	7"
225	8"	7"
250	9"	8 ¹⁵ / ₁₆ "
275	10 ¹³ / ₁₆ "	8 ¹⁵ / ₁₆ "
300	11"	10 ¹⁵ / ₁₆ "
350	13"	10 ¹⁵ / ₁₆ "



#B504 Blue



#C386 Red



#065 Industrial Gray

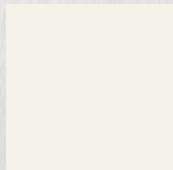

#445 White



#F604 Pebble

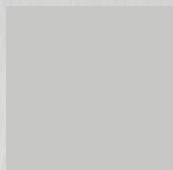

#161 Mist Gray

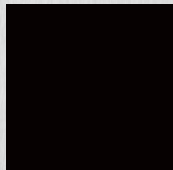

#040 Black

Why Borroughs?

Borroughs knows how important your service department can be to you and your organization. That's why we produce high quality, flexible shop equipment. We insist that our distributors are thoroughly trained and knowledgeable concerning the specialized requirements of your dealership. The extra effort and careful planning our distributors provide will assure a service department that is efficient and attractive.

Your Borroughs Distributor offers everything from layout assistance to timely delivery and installation. Your distributor will be there long after your equipment has been installed to answer questions and contribute ideas.

For All Your Dealership Requirements

- Service Writer Desks
- File and Record Storage
- Tear-Down Benches
- Essential Tools Storage
- Tire and Battery Storage
- Parts Department Equipment

Borroughs Standard Powder Coat Colors

Borroughs powder coated finishes are high quality, durable and inert. Six standard industrial (automotive) colors, available with no up-charge are: #B504 Blue, #C386 Red, #065 Industrial Gray, #445 White, #F604 Pebble, #161 Mist Gray and #040 Black. We also offer custom color matching using Borroughs computerized technology.

The colors depicted on this publication have been reproduced using a printing process and are only provided as a guide. The actual painted product may vary. All colors are not available on all products. Please contact your Borroughs Distributor for details.



3002 N. Burdick Street • Kalamazoo, MI 49004-3483
800.748.0227 • Fax: (269) 342.4161 • www.borroughs.com